

Bluetooth Stereo Headset + Stereo Adapter



BTST-9300D



Thank you

Thank you for purchasing the Bluetooth Stereo Headset. The Headset is designed for audio device users to have a high quality stereo sound and a wireless operating range up to 10 meters. Please read the instruction manual to make the best use of the Headset. We hope you will enjoy the high quality stereo sound and power of Bluetooth wireless technology.

Box content

- Bluetooth stereo headset
- Bluetooth stereo adapter
- Power Adapter
- User guide

Overview

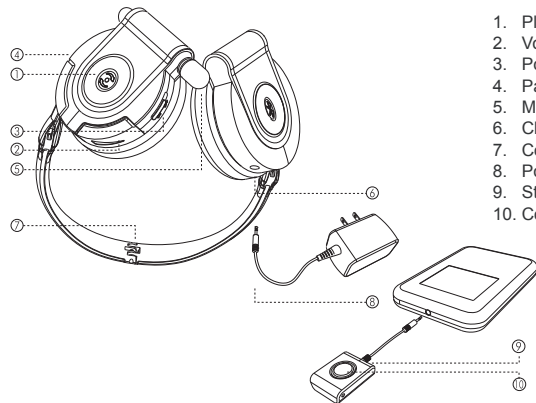

2

Getting Start

1 Charge battery

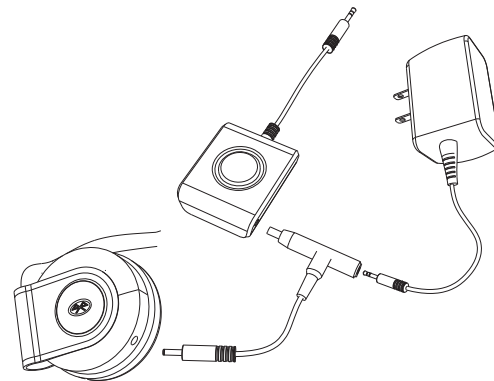

- Connect the power adapter to the T-connector.
- Connect the stereo headset and adapter to the T-connector
- Plug the power adapter into an electrical outlet.

Note:

For the first time use, it takes 4 hours to fully charge the batteries and 2 hours afterward. With the batteries fully charged, the use time is around 6.5 hours and the standby time is around 230 hours.

3

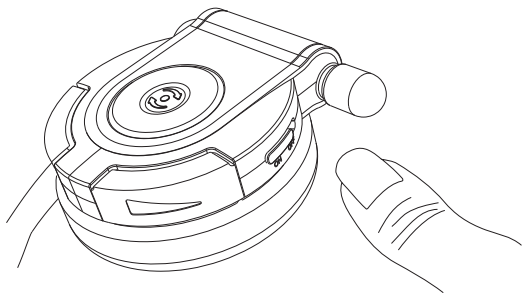
2 Power On

- Use the power switch to turn on the power

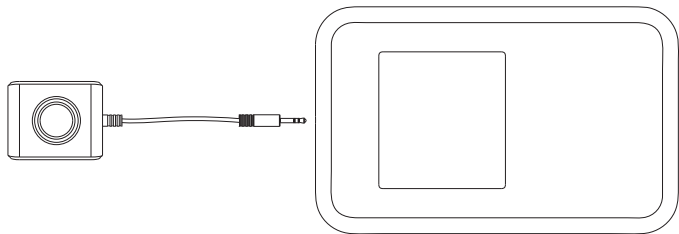
3 Plug into the audio device

- Plug the audio connector into the audio port of the audio device.

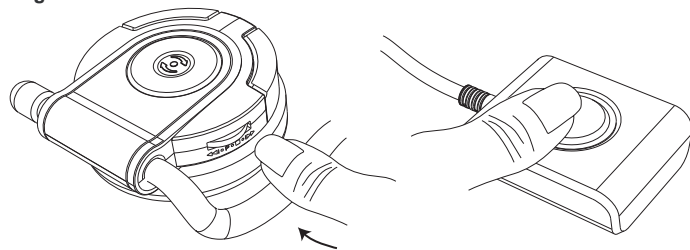
4 Pairing

- Press and hold the pairing wheel on the stereo headset for 6 seconds until the blue and red LEDs flash alternately.
- Press and hold the control button on the stereo adapter for 6 seconds until the blue and red LEDs flash alternately.

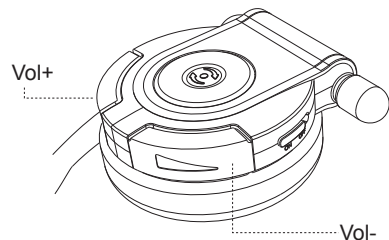
5 Volume Control

- Use the volume buttons on the stereo headset to adjust volume.

Note:

Since output voltage of audio devices varies from one to another, for users to have best sound quality, the stereo adapter offers users 2 volume modes, high volume mode and normal mode.

6 Set volume mode

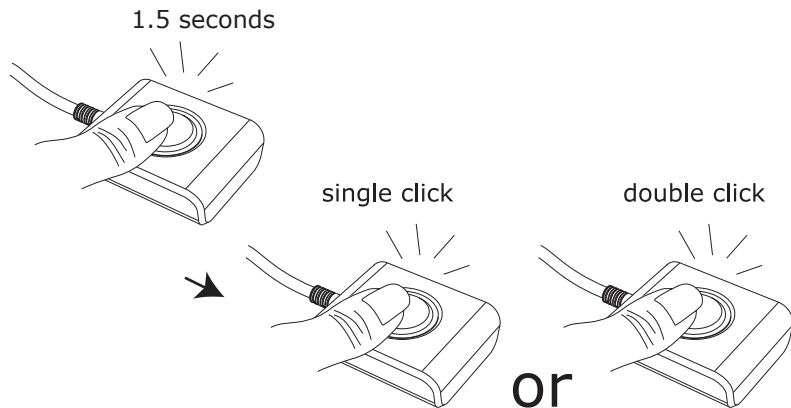

Normal volume mode

- Press and hold the control buttons on the stereo adapter for 1.5 seconds to disconnect the stereo adapter from the audio device.
- Single click on the control button will reconnect the stereo adapter to the audio device and set the stereo headset to normal volume mode.

High volume mode

- Press and hold the control buttons on the stereo adapter for 1.5 seconds to disconnect the stereo adapter from the audio device
- Double click on the control button will reconnect to the stereo adapter to the audio device and set the stereo headset to high volume mode.

Note:

- For iPod, normal mode is preferred.
- For Sony PSP or Creative MP3 player and others, high volume mode is preferred.

Use with mobile phone

1 Pairing

Press and hold the pairing/track wheel button on the stereo headset for 6 seconds to set the stereo headset into pairing mode. The blue and red LEDs will be flashing when the stereo headset is in pairing mode. To properly perform pairing procedure on your mobile phone, please refer to the manual of your mobile phone for its own pairing instruction. This device name is set to be "Bluetooth Stereo Headset". If you are asked to enter pin-code during pairing, please enter 1234. (Note: The "1234" is default pin-code pre-stored in this Stereo headset.)

2 To make a call

- Dial out the number from your mobile phone.
- Voice is automatically transferred to the headset.

3 To receive a Call:

1. When there is an incoming call, press the answer button to answer the call and the audio channel will be switched to the mobile phone.

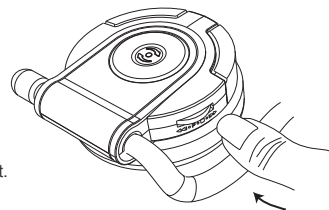

2. Press the Volume control button to adjust the volume.
3. When finish talking, press the answer button to end the call and the audio channel will be switched back to the audio device.

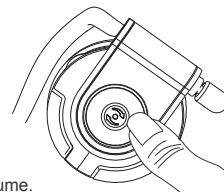

4 To reject a Call

- Press the reject button on the mobile phone to reject a call.

Use with computer device

The stereo headset can also be used with Bluetooth enabled computer device, such as PC, notebook, and PDA. The stereo headset includes a special designed track wheel and play on/off button that provide users with an easy control to Windows Media Player.

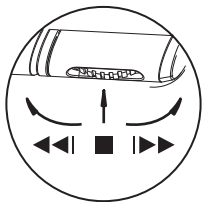

Note:

- "A2DP profile" is required to support stereo sound.
- For details on pairing, please follow the Bluetooth driver's user guide and pairing instruction under "**Use with mobile phone**" in this manual.

Use with audio player and mobile phone at same time.

- 1). The stereo headset needs to be paired and connected with both devices.
- 2). When there is an incoming call, a notice tone will be played from the stereo headset.
- 3). Users can press the answer button on the stereo headset to answer the call or press the reject button on the mobile phone to reject the call.

Use with TV or HI-FI system

- To use the stereo headset with TV or HI-FI system, user might need to obtain a "RCA to phone jack cable".
- Since different systems have different electrical characteristics, the audio volume of the stereo headset could be affected by the output power of the TV/HI-FI system.

Important Information

Product care

- Use of non-original accessories may result in performance deterioration, injury, products damage, electronic shock, and warranty termination.
- Attempt to disassemble your stereo headset or stereo adapter may damage it, and the warranty will be void.
- Always store the Headset with the power turned off.
- Avoid exposing the Headset to direct sunlight or other heat source.
- Do not expose the Headset to water or other liquids.

Children

Please keep the stereo headset and stereo adapter away from children, as the small parts may cause choking hazard.

Battery Information

- New batteries
 - For time first time use, please charge the battery for at least 4 hours.
- Battery care
 - Only qualified Service Centers are authorized to remove or replace the battery.
 - The rechargeable battery has a long service life if treated with care.
 - The battery can only be charged in a temperature range of -10C to 45C.
 - The battery capacity may be reduced if operating in a cold environment.

About Pairing

What is pairing?

Pairing is a process of associating Bluetooth devices with each other. It will establish a permanent security link between the devices and enable quick access to the services provided without the need to enter passkeys.

Bluetooth Passkey

The Bluetooth Stereo Headset has a default passkey **1234** for pairing, which is stored in its internal memory. Usually users are required to enter the passkey **1234** in a pairing process with a Bluetooth mobile phone or other devices; however it depends on the kind of Bluetooth device that the stereo headset is connected to. Please refer to the users' manual of the devices for the specific operation.

Note:

The paired devices remain paired even when both of the devices are powered off, or when a service connection is interrupted or stopped.

FAQ

- Can I change Bluetooth passkey?
No, the Bluetooth is written into the device when it manufactured and cannot be changed.
- Can I use stereo headset with audio device and mobile phone at same time?
Yes, the stereo headset can be used with audio device and mobile phone at same time. However, there could be some compatibility issues on certain brands of models of mobile phones.
- Can I use stereo headset while it is in charging mode?
No, the stereo headset cannot be used while it is in charging mode.
- What is the operating range of the Headset?
The operating range of the Headset is up to 10 meters.

- Do I need to pair the stereo headset with my mobile phone and Bluetooth stereo adapter every time I use it?
You need to pair the stereo headset with your mobile phone and Bluetooth stereo adapter when first time using it. You only need to reconnect the stereo headset with your mobile phone and Bluetooth stereo adapter afterward.
- How come the track control does not work with my MP3 player?
The track control is a special feature designed for Windows Media Player. It doesn't apply to MP3 player because most of MP3 players do not support such functions.
- Can I use the Stereo headset with mobile phone to listen to music?
If your mobile phone is Bluetooth enabled and supports stereo feature (A2DP), then you can use the stereo headset with your mobile phone to listen to music. However, most of Bluetooth enabled phones do not support such feature.

Troubleshooting

- The track control is not working.
 - The track control is designed for Windows Media Player only.
 - Make sure that you are using Windows Media Player.
- Music is on and off when the stereo headset is paired with audio device/pc and mobile phone.
 - When users try to use stereo headset and audio device / pc at same time, there could be some compatibility issues on certain brands of models of mobile phones. However, this problem shouldn't occur when use stereo headset with single device.